

इंटरनेट

मानक

Disclosure to Promote the Right To Information

Whereas the Parliament of India has set out to provide a practical regime of right to information for citizens to secure access to information under the control of public authorities, in order to promote transparency and accountability in the working of every public authority, and whereas the attached publication of the Bureau of Indian Standards is of particular interest to the public, particularly disadvantaged communities and those engaged in the pursuit of education and knowledge, the attached public safety standard is made available to promote the timely dissemination of this information in an accurate manner to the public.

“जानने का अधिकार, जीने का अधिकार”

Mazdoor Kisan Shakti Sangathan

“The Right to Information, The Right to Live”

“पुराने को छोड़ नये के तरफ”

Jawaharlal Nehru

“Step Out From the Old to the New”

IS 11150 (1993): Construction of concrete barrages - Code of practice [WRD 22: River Training and Diversion Works]



“ज्ञान से एक नये भारत का निर्माण”

Satyanarayan Gangaram Pitroda

“Invent a New India Using Knowledge”



“ज्ञान एक ऐसा खजाना है जो कभी चुराया नहीं जा सकता है”

Bhartrhari—Nitiśatakam

“Knowledge is such a treasure which cannot be stolen”

BLANK PAGE



भारतीय मानक

कंक्रीट बाँध की संरचना — रीति संहिता

(पहला पुनरीक्षण)

Indian Standard

**CONSTRUCTION OF CONCRETE BARRAGES —
CODE OF PRACTICE**

(First Revision)

UDC 627-82-012-4 : 006-76

© BIS 1993

**BUREAU OF INDIAN STANDARDS
MANAK BHAVAN, 9 BAHADUR SHAH ZAFAR MARG
NEW DELHI 110002**

FOREWORD

This Indian Standard (First Revision) was adopted by the Bureau of Indian Standards, after the draft finalized by the Barrages and Weirs Sectional Committee had been approved by the River Valley Division Council.

Agriculture plays an important role in the economy of our country. For proper development of agriculture, we need to ensure irrigation facilities by tapping the river water and taking it to fields through canals. Diversion of water from rivers is achieved by the construction of barrages and weirs across them. With increased emphasis on agriculture in our planning, these diversion structures are also becoming important in terms of their use and money spent on them. A need has thus been felt to lay down guidelines for the construction of barrages and weirs on permeable foundations as well as bouldary strata. The design part has been covered in IS 11130 : 1984 'Criteria for structural design of barrages and weirs'.

Some information regarding dewatering methods and sheet piling adopted in the construction of some important barrages in India are given in Annexes A and B for general guidance.

This standard was first published in 1984. The revision of this standard has been taken up to incorporate the latest practices prevailing in the field.

For the purpose of deciding whether a particular requirement of this standard is complied with, the final value, observed or calculated, expressing the result of a test or analysis, shall be rounded off in accordance with IS 2 : 1960 'Rules for rounding off numerical values (*revised*)'. The number of significant places retained in the rounded off value should be the same as that of the specified value in this standard.

AMENDMENT NO. 1 APRIL 2010
TO
IS 11150 : 1993 CONSTRUCTION OF CONCRETE
BARRAGES — CODE OF PRACTICE

(First Revision)

[Page 1, clause 3.1] — Substitute 'IS 4410 (Part 8) : 1992' for 'IS 4410 (Part 8) : 1968'.

[Page 1, clause 4(h)] — Substitute 'Location and accessibility of potential quarry areas for coarse and fine aggregates and identification of source of quality flyash' for 'Location and accessibility of potential quarry areas for coarse and fine aggregate'.

[Page 2, clause 5.1.1(g), line 4] — Add 'flyash' after 'cement'.

[Page 2, clause 5.1.1(m), line 2] — Add 'flyash' after 'soils'.

[Page 2, clause 5.1.2(c)] — Substitute 'Procurement of commodities, such as cement, flyash, coarse and fine aggregates, structural and reinforcement steel, sheet piles, explosives etc; and' for 'Procurement of controlled, scarce and unperishable commodities, such as cement, sheet piles, structural and reinforcement steel, aggregates, explosives, etc; and'.

[Page 3, clause 5.3(d)] — Substitute 'Availability and procurement of essential materials like cement, flyash, coarse and fine aggregates, steel and sheet piles' for 'Availability and procurement of essential materials like cement, steel, sheet piles and coarse aggregate'.

[Page 7, clause 6.3(f)(1)(ii); line 7] — Substitute 'IS 456 : 2000' for 'IS 456 : 1978'.

[Page 9, clause 6.3(h)(3)] — Add the following new sub-paragraph at the end:

'4) In case ordinary Portland cement is used for *in-situ* concreting or precasting of concrete blocks, it may be replaced by flyash to the maximum extent of 35 percent by weight. However, the actual quantity of flyash as a replacement of material of the cement shall be assessed on the basis of design of the concrete mix for achievement of the desired workability and ultimate compressive strength.'

Amend No. 1 to IS 11150 : 1993

[Page 9, clause 6.3(j)(3)(iii)] — Add the following new item at the end:

'iv) Flyash conforming to IS 3812 : 1981 can also be used as backfill material'.

[Page 10, clauses 8.2 and 8.3] — Substitute 'IS 456 : 2000' for 'IS 456 : 1978'.

[Page 10, clause 9.1] — Substitute 'IS 7349 : 1989' for 'IS 7349 : 1974'.

(Page 12, Annex C) — Substitute the following for the existing entry:

'IS 456 : 2000 Plain and reinforced concrete — Code of practice (*fourth revision*)'.

(Page 12, Annex C) — Add the following standard in the list:

'IS 3812 : 1981 Specification for fly ash for use as pozzolana and admixture (*first revision*)'.

(Page 12, Annex C) — Substitute the following for the existing entry:

'IS 4410 (Part 8) : 1992 Glossary of terms relating to river valley projects : Part 8 Dams and dam sections (*first revision*)'.

(Page 12, Annex C) — Substitute 'IS 9795 (Part 1) : 1981' for 'IS 9795 (Part 1) : 1987'.

*Indian Standard***CONSTRUCTION OF CONCRETE BARRAGES—
CODE OF PRACTICE***(First Revision)***1 SCOPE**

This standard covers construction of concrete barrages on permeable foundations including care and diversion of river during construction.

2 REFERENCES

The Indian Standards listed in Annex C are necessary adjuncts to this standard.

3 TERMINOLOGY

3.1 For the purpose of this standard, the following definition and definitions given in IS 6966 (Part 1) : 1989, IS 1191 : 1971, IS 4410 (Part 3) : 1988 and IS 4410 (Part 8) : 1968 should apply.

3.2 Dewatering

It is lowering of water table to facilitate construction of the barrage substructure and connected works in fairly dry condition either by means of well-point system, deep-well pumping, surface or open pumping, or any other method and/or suitable combination of methods adopted to suit the site conditions. The method adopted should be such that uninterrupted dewatering is possible to keep the water table at least 300 mm below the levels at which permanent works are constructed and free flow of particles below the foundation is prevented.

4 DATA REQUIRED

For efficient and economical construction of barrages detailed information with regard to the following should be made available for construction :

- a) An index map of suitable scale showing the proposed site of work with position of important irrigation works, roads and railway crossing electric transmission, rain gauge and discharge observation sites near the barrages site;
- b) A contour plan of the area around the proposed site of the barrage with contour intervals of not more than 0.50 to 1.0 m and up to an elevation of 2.50 to 6.0 m above the high flood level depending upon the terrain conditions; it should cover the store yard, labour shed area, colony, workshop, aggregate processing and concrete batching and mixing plant, etc;
- c) Cross-section of the river at the proposed site and at intervals of 50 to 200 m both on upstream and downstream up to at least 600 m from the proposed site;
- d) Log charts of bore holes drilled at about 50 to 100 m intervals depending upon the length of the barrage, along the divide walls and under abutments, to a depth of at least 10 m below the deepest river bed level. Such log charts along the upstream and downstream cut-off lines should indicate the bottom level of cut-off;
- e) Permeability tests conducted for assessing seepage below the structure for designing the scheme for dewatering and planning of the equipment. The depth of logging below divide wall should be as required by design requirements;
- f) Daily rainfall data in and around the catchment area for as many years as available;
- g) Information regarding the river geometry, flood discharges (with their duration) and corresponding high flood levels, fair weather discharges and minimum water levels for as many years as possible prior to construction;
- h) Location and accessibility of potential quarry areas for coarse and fine aggregate;
- j) Working drawings of the barrage and appurtenant works including details of excavation, reinforcement, instruments, embedments and block outs for gates and hoists, joints, seals, etc;
- k) Sequence of construction of various blocks comprising of number of bays and abutments, etc;
- m) Various constraints on different activities of construction, such as well, cut-offs, pile drying, etc;
- n) Inter-dependence of various items so that there is minimum interference in the continuity of progress;
- p) Necessary precautions to be taken for protection of season's works from ensuing floods and also freshets during the working season; and

- q) Special features of construction of barrages, if any.

5 CONSTRUCTION PLANNING

5.1 The construction planning of concrete barrages is broadly classified as in 5.1.1 and 5.1.2.

5.1.1 Infrastructure Planning

This includes approach roads, power and water supply, workshop, stores, aggregate processing plant, concrete batching and mixing plants, camps and workshops and establishment of other amenities, such as market, fair-price shops, school, medical facilities and other social and cultural needs of the field staff and workers. The planning should be carried out to the extent possible before the work is started, so that the uncertainties and delays in the execution of work, and precise time estimates for the job planning could be evaluated. The requisites of infrastructure and other facilities should be as under:

- a) Site clearance;
- b) Construction of major and medium access roads to site. These roads should be black-topped to withstand the traffic intensity of heavy vehicles needed for the execution of works;
- c) The haul roads, required for the disposal of the excavated material, should be constructed after finalising the job planning;
- d) Bridges enroute to site should be designed to cater for loads of construction equipment, such as shovels, cranes, tippers, etc;
- e) Adequate power supply from the grid at points of consumption should be supplied. A generating station having adequate capacity to meet the power requirements of critical items of work, such as dewatering, should be installed at site, to ensure uninterrupted power supply. In case power supply is not available at site from grid, generating stations to meet the peak power requirements for different construction activities should be set up at site;
- f) Water supply for the works;
- g) Railway siding facilities for loading/unloading of heavy machinery and equipment, essential commodities, such as cement and high speed diesel, should be arranged at the nearest rail-head to the project site;
- h) Telephone, telegraph and other communication facilities required for the project site;

- j) Acquisition of land for works, both for departmental and contractor's colonies;
- k) Location of approved quarries for stone aggregates and sand should be decided. Access road and power supply for the quarry-sites should be arranged;
- m) A well equipped laboratory for sampling, testing of soils, materials and formulating of design mixes for concrete, etc should be provided;
- n) Temporary hospital with medical equipment should be provided; and
- p) Planning for housing of construction workers, provision of sanitary amenities and fuel supply for the colony is necessary for preventing deterioration of surrounding environment.

5.1.2 Procurement Planning

- a) Establishment of magazine of adequate capacity and procurement of initial requirements of explosives;
- b) Establishment of adequate storage of P.O.L.;
- c) Procurement of controlled, scarce and unperishable commodities, such as cement, sheet piles, structural and reinforcement steel, aggregates, explosives, etc; and
- d) Procurement of necessary construction equipment, spare parts and accessories.

5.2 Programme of Works

The programme of works should consist mainly of the following:

- a) Bar chart programme for the project duration showing the quantities and monthly progress required for various major items of the project should be prepared. It would be desirable to work out a master network plan based on PERT/CPM planning for monitoring the project and this is to be reviewed before start of every working season or earlier;
- b) Based on the project duration and time analysis of various activities, resource-planning, for example, planning of finance, manpower planning and equipment planning for various activities in the different seasons of work should be prepared;
- c) Manpower planning should indicate the seasonwise requirement of various categories of officers and staff. Monthly, daily rated workmen and piecework labour for the execution of the season's programme should also be planned;

- d) Equipment planning should indicate the seasonwise requirement of various plant and equipment with important spares and accessories; and
- e) The requirement of finances for the season's work should be worked out by preparing fund-flow analysis and cash-flow sheets. This would enable the project authorities to forecast the borrowings, capital investment and various other aspects of financing the job.

5.3 Review of Programme and Resources

It should indicate the following:

- a) The budgeted programme of work and actual progress achievement should be reviewed every quarter and monitoring of the resources should be carried out to obviate the shortfall in progress;
- b) The actual performance of various machines should be compared with estimated performance and necessary corrective measures should be taken to improve the performance;
- c) The budgeted cost of various major items should be compared with actual costs and necessary measures to control the costs should be adopted;
- d) Availability and procurement of essential materials like cement, steel, sheet piles and coarse aggregate;
- e) Accessories and spare parts for plant and machinery in use; and
- f) Availability of skilled and unskilled manpower.

6 SEQUENCE OF CONSTRUCTION

6.1 Layout of a typical barrage showing the various items of works is shown in Fig. 1. To establish the barrage axis as per the approved plan, *pucca* axis pillars should be constructed at suitable locations not to be disturbed by construction works and river water level.

6.1.1 Bench mark should be carried to the project area and established at different places and their locations and values recorded.

6.2 In order that the final stress pattern in the completed structures conforms as closely as possible to that assumed in the design, it is necessary that the design organization specify the essential conditions governing the sequence of construction. The actual sequence should be subject to approval by the Engineer-in-charge before construction starts on any of the structural items of the barrage and this sequence should not be materially varied without his approval.

6.3 The following sequence of construction should generally be adopted at the various stages of the construction work:

- a) Temporary access bridge should be provided for transport of man, materials, and equipment whenever necessary;
- b) The layout of coffer dam enclosure should be decided on the site conditions, nature of river course, and programme of works for the season [Reference may be made to IS 9795 (Part 1) : 1981 and IS 10084 (Part 1) : 1982];
- c) *Dewatering* — The following points should be taken care of while dewatering:
 - 1) After completing the excavation above the water table dewatering of the foundations should be commenced by well points/open pumps/deep-well pumps and the water table progressively lowered.
 - 2) In sandy soil well point systems may be suitable for dewatering. In silty clay foundations strata open pumps and/or deep well pumps may be suitable. If an impermeable compact shingless-cobble layer is sandwiched between sandy layers in the depth to be excavated, deep-well pumps with strainer throughout the depth of the tubewell will be suitable.
 - 3) The bore hole details indicating the foundation strata, soil characteristic namely, grain sizes, distribution, relative density and permeability should be examined before deciding on the system of dewatering.
 - 4) The preliminary requirements of dewatering pumps should be based on the inflow to the work area, calculated on the basis of permeability of the strata and closeness of the water source/ sources.
 - 5) The designs, installation and operation of dewatering system should be in accordance with IS 9759 : 1981.
 - 6) During dewatering operation, care should be taken to ensure that there is no removal of fines from the sub-strata that may weaken the foundation.
 - 7) Any seepage of water from the foundation at local points or springs should be taken care of properly so that there is no piping of the foundation material.

d) Excavation of the foundation to the barrage profile is to be made either manually or by machines in reasonably dry condition. During excavation, water table should be maintained at a lower level than the level at which excavation is being done. The excavated soil should be disposed of either manually or by machines, to suit site requirements. In case, machinery is employed for excavation, final excavation of the lowest layer should be done manually to the specified depth;

e) *Cut-off walls*

1) *Sheet pile cut-off walls in non-bouldary reaches*

The sequence of construction should be as follows:

- i) After excavation to the final profile or very near to the final profile is completed, driving of sheet piles for cut-offs may be started;
- ii) Sheet piles should be driven vertically in pairs, with bulb forward, by means of cranes, or pile frames using drop hammers, single/double acting hammers or vibrosinkers depending on the availability and suitability of machines with respect to soil characteristics of the barrage foundation. It may not always be possible to drive the sheet piles vertically plumb. Whenever the piles lean beyond the permissible limit, suitable taper piles should be provided to correct the verticality;
- iii) Welding of piles prior to driving, or welding *in situ* to make up the required length may normally be permitted. Driving of welded sheet piles of more than 8 m length is, however, not considered safe as weld may give way under high driving stresses;
- iv) Cross-sheet piles under double piers in the raft type design, connecting the upstream and downstream cut-offs and sheet piles near the junctions should be driven with proper precautions, as regards the verticality of piles;
- v) Sheet piling for abutments, return walls and flared out walls should be taken up simultaneously, wherever possible, to ensure easier and vertical driving;
- vi) Sheet piles if used for temporary protection works may be permitted

to be left in place if their extraction is likely to endanger the safety of the structure, due to disturbance of foundation-strata during extraction. However, after completion of the work, the head of the piles are to be cut off up to bed level;

vii) Wherever seals are provided and are to be joined to the sheet piles, it should be carefully done by welding and brazing or bolting, as necessary;

viii) Since sheet piles are designed to have hinge action at the top, it should be ensured by provision of tar paper wherever two pile rows are provided side by side. Cork mastic filter on top may be provided to take care of uneven heights and hinge action.

2) *Cut-off walls in bouldary strata*

The barrage founded on bouldary strata should be constructed either with concrete diaphragm wall cut-off or installation of steel sheet pile cut-off in preformed trenches backfilled with sand. The sequence of construction should be as under:

i) Concrete diaphragm wall cut-off:

- A) Excavation of the trench for the concrete diaphragm through sub-soil should be done with suitable trenching machine capable of ensuring that the width of trenches excavated should conform to the thickness of diaphragm wall,
- B) The excavation of the trench should be carried out by means of bentonite slurry circulation method to enable tremieing concrete for construction of diaphragm cut-off. The sides of the trench should be suitably maintained before and during the concrete to prevent any caving-in,
- C) After formation of the trench, reinforcement cage in accordance with design requirements and predetermined panel lengths should be lower into the cut-off trench,
- D) The concrete of requisite strength should be placed in such a manner that the concrete displaces the slurry and

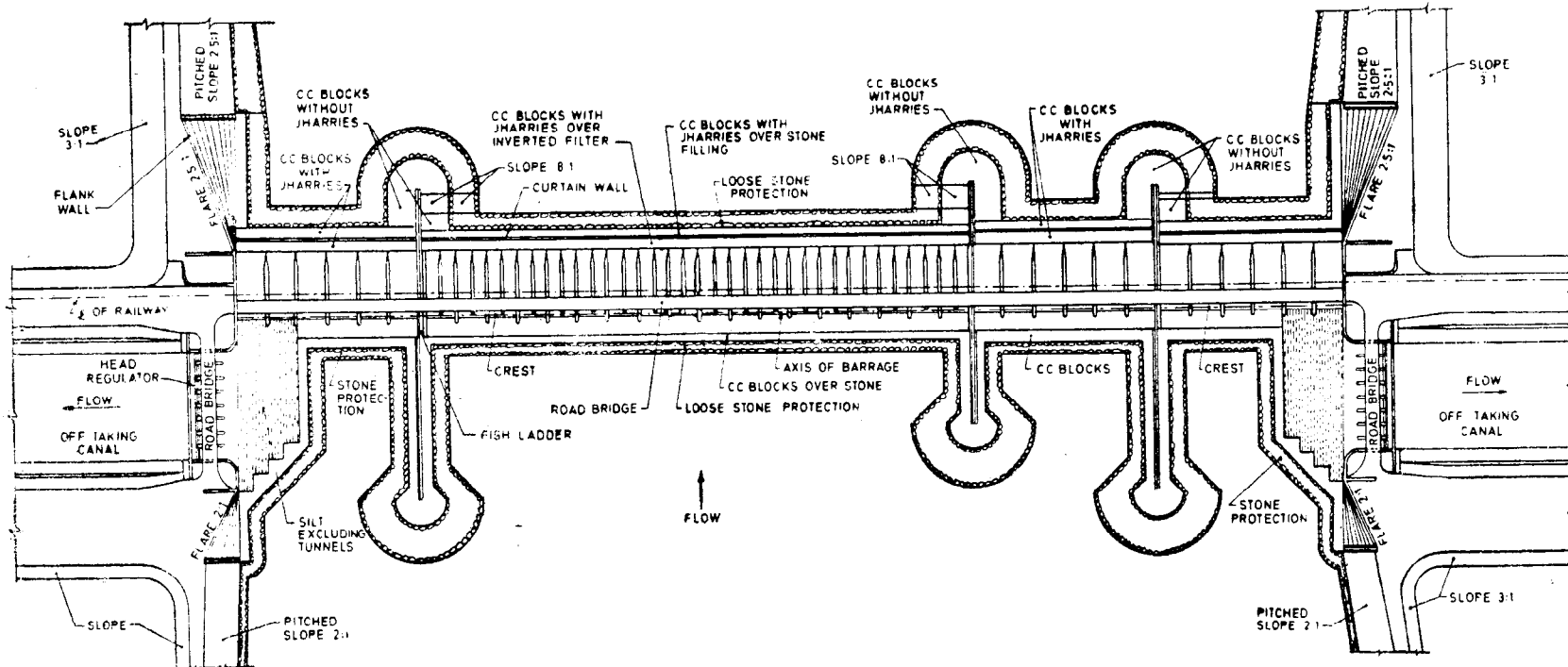

FIG. 1 TYPICAL LAYOUT OF A BARRAGE

As in the Original Standard, this Page is Intentionally Left Blank

- mixing of concrete with slurry does not occur. The tremie should be watertight and sufficiently large to permit free flow of concrete, and all precautions should be taken to get good quality of concrete;
- E) The placement of concrete should continue without interruption until the concreting is completed up to required elevation in the section or panel, of the wall under construction;
- F) To connect the joints between the wall panels, shoulder pipe or any other method as recommended should be used. The joints between the concrete diaphragm panels should be pressure grouted with cement grout as considered necessary, so as to ensure a continuous unbroken cut-off;
- ii) Sheetpile cut-off in preformed trenches backfilled with sand:
- A) A trench along the sheetpile cut-off line, of suitable width (generally 600 mm wide) should be formed by bentonite method as described in 6.3 (e) (2) (i) (A) and (B);
- (B) The preformed trench should be back-filled with locally available sand by replacing the bentonite slurry and the bentonite washed out by compressed air and waterjet injected in the backfilled sand; and
- C) Steel sheet pile cut-off should be installed in the preformed trench, in accordance with sequence enumerated in 6.3 (e) (1);
- iii) In case of localised rocky strata being encountered, the excavation should be done by using jumpers, chisels, paving breakers, etc, and not by blasting in any case.
- 3) *Foundation preparation and instrumentation*
- i) Once the cut-off walls on upstream and downstream sides of the barrage are installed and pile caps partially completed, the foundation surface should be properly levelled, dressed and consolidated;
- ii) The foundation should not contain loose pockets or materials and they should be watered and compacted to the specified relative density, if necessary by vibro-rotation technique;
- iii) Clay pockets should be treated as specified by the designer. It has to be ensured that proper drainage arrangements in the foundation according to the designs including inverted filter, wherever indicated, are provided and concreting work is taken up; and
- iv) Piezometers, pressure cells, soil-stress meters, tilt meters and other instrumentation as specified should be installed. Care should be taken to protect these instruments and their connections during subsequent operations (see relevant Indian Standards concerning these aspects for guidance).
- f) *Concrete*
- Batching, mixing, placing and protection of concrete should be done in accordance with IS 456 : 1978. Block-out should be provided for embedded parts in accordance with drawing. The following sequence of operations should be adopted for various concrete items:
- 1) *Pile caps:*
- i) Pile cap for sheet piles should be laid with the concrete floor. However, pile caps may be constructed in advance to serve as a retaining barrier for taking up concrete apron blocks;
- ii) Normally the pile caps are taken deeper than foundation level and it may be necessary at times that concreting of portion of pile caps may have to be done in underwater condition. This should be done in accordance with IS 456 : 1978. The balance portion of the pile cap should be done along with the main structure taking proper care for treatment of the joint;
- iii) Dowel bars or if necessary, metal sealing strips should be provided for the joints between the pile caps and the barrage floor. The sealing strip, if provided, should be properly and securely braced with the sheet piles and the concrete should be carefully placed

against the faces of the vertical joints and the sealing strips so as not to disturb the water seal; and

- iv) In case of boundary strata, where diaphragm wall cut-off is provided, similar arrangement of dowel bars or sealing strip should be provided to seal the joint between the cut-off wall and the barrage floor. Rubber, PVC or metal sealing strips should be provided and proper precautions should be taken while concreting, so as not to disturb the water seals.

2) *Barrage bays, silt excluder and piers:*

- i) If it is envisaged to place the concrete in barrage bays and piers by means of cranes, the cranes may be located on the upstream and downstream of barrage. General arrangement of location of cranes for placement of concrete is shown in Fig. 2; and
- ii) The sequence of concreting of various lifts, starting from downstream end of the barrage and with continuous pour in suitable layers, or as specified by the Engineer-in-charge.

3) *Abutment and flared out walls:*

- i) In case of pile foundations, the piles should be driven to the founding levels and pile caps and foundation raft should follow; and
- ii) In case of well foundations, the sequence of construction as enumerated for divide wall in 6.3 (g) should be adopted.

g) *Divide wall well foundations:*

The wells should be sunk to the founding levels and the work of barrage bays on either side of the divide wall should be taken up after construction of well including well-caps.

h) *Cement concrete/colcrete blocks:*

- i) In case of cast *in-situ* blocks, alternate blocks should be concreted or a proper pattern of concrete sequence should be established for economical use of block shuttering. The formwork should be so designed that when it is stripped off, the required gap is formed for filling filter material. For casting the upstream protection blocks shuttering oil should be applied on the surface of the blocks already cast.

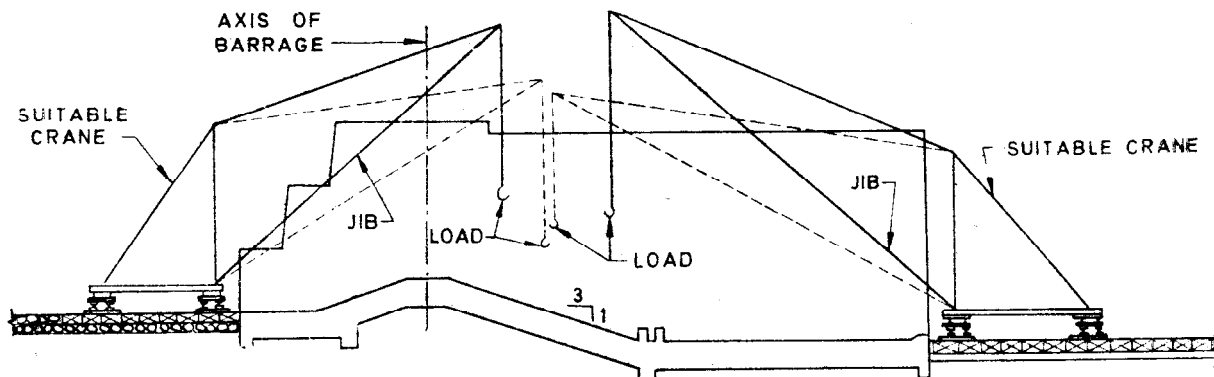

DISPOSITION OF CRANES (TYPICAL ARRANGEMENT)

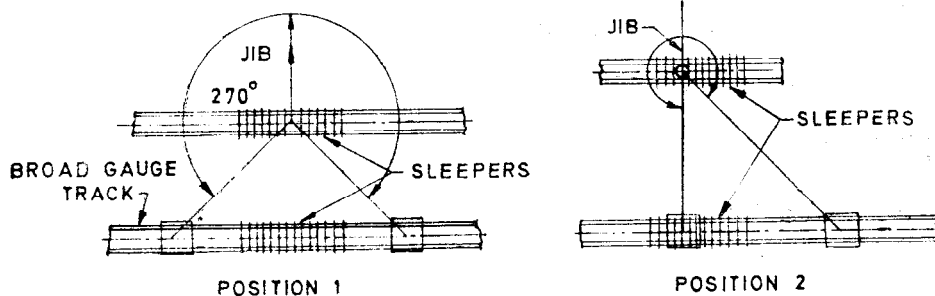

FIG. 2 TYPICAL CONCRETING ARRANGEMENT BY CRANES OF BARRAGE SPILLWAY

- 2) Colcreting of cast *in-situ* blocks should be permissible. For colcrete blocks, aggregates should be placed into shuttered boxes of requisite sizes and hand packed before colgrouting. The proportion of colgrout should be as specified by Engineer-in-charge.
 - 3) To facilitate speed of construction, precasting of blocks may be allowed.
-) *Miscellaneous Works*
- 1) *Construction of bridge*
 - i) The bridge over the barrage should be either in reinforced concrete or prestressed concrete and should be constructed in accordance with approved design and drawings;
 - ii) The sequence of construction of bridge spans over the completed barrage piers should be synchronised with the programme of completion of barrage piers, from either bank, and will be mainly dependent on the plant set-up and other infrastructural facilities at site;
 - iii) It may be a possibility in major barrages with large number spans, to take up construction of bridge over the completed piers from one end as a parallel activity while the work on the balance barrage bays and piers is under construction. While the main barrage and bridge over the barrage are being constructed concurrently, proper arrangements for conveying and feeding of concrete to various placement points should be made to facilitate speeding-up of work;
 - 2) *Erection of gates and hoists*
 - i) Detailed planning of various activities of erection of hydro-mechanical equipment should be made so that works on other items under progress do not hamper;
 - ii) The erection of gates and hoists can be started after completion of the bridge over the barrage; and
 - iii) Layout of the crane-track for the crane to be utilised for erection of hydro-mechanical equipment should be suitably planned so that the other activities on the construction of bridge go on smoothly and the portion of the road bridge is also available for haulage of men, materials, equipment, etc for other works on barrage.
 - 3) *Backfill of retaining structures*
 - i) Backfill comprising of earth or rockfill should be placed at locations indicated in the approved drawings;
 - ii) All backfill materials should be graded to lines and grades, and should be drawn from the excavated materials as far as possible; and
 - iii) The compacted backfill should be done in layers not exceeding 225 mm with approved type of pervious soil. The optimum moisture content and relative density should be in accordance with the approved design/specifications.
 - 4) *Construction of approach banks, guide bunds, afflux bunds, etc*
 - i) The work on the construction of approach, afflux and guide bunds may be taken up from the farther-ends to suit the construction programme of the main barrage; and
 - ii) After completion of retaining structures, such as abutments, return walls and flare out walls of the barrage to the required levels, the embankments of approach banks, guide bunds and afflux bunds should be completed and keyed to the main barrage structure according to the approved drawings.
 - k) *Head regulators*
The construction sequence of head regulators should be similar to the construction sequence of barrage.

7 CARE AND DIVERSION OF RIVER

7.1 Appropriate hydraulic model tests may be required to be carried out for the barrages to assess the flow pattern, velocities around the nose, afflux in the river, etc so that the magnitude of construction and hydraulic problems could be evaluated and corrective steps taken.

7.2 The programme of construction of river diversion work should mainly be determined by the availability of working period, likely time that would be required for construction of coffer-dams, associated diversion works and construction capability.

7.3 The period available for construction of cofferdams is generally limited and depends on the post-monsoon pattern of the river course and quantum of discharge and programme of work of various items of permanent nature.

7.4 Cofferdam construction for the portions nearer to the river banks where the velocities may not be high, may be earthen type cofferdams and when the works advance into river portion, composite type of cofferdams consisting of single sheet piles backed with earthen embankments may be provided. Suitable protection on the river side be provided to avoid dislodging of sheet piles due to scour of the soil backing.

7.5 The mode of construction of cofferdams should be governed by the site conditions and the extent of earthwork, sheet piling, and other protection works involved and should be assessed for each project.

7.6 The construction drawings for the diversion works should indicate the suitable provisions for the protection of unfinished work at the end of construction season, during the floods.

NOTE — The design of cofferdams is governed by many factors namely, design flood discharges, velocities, afflux, etc [see IS 10084 (Part 1) : 1982].

7.7 The construction equipment and resources should be estimated on the basis of the quantum of work and the availability of time period for the execution of the cofferdams.

8 CONCRETE WORKS

8.1 Formwork

8.1.1 The formwork should be preferably in steel, except for the curved surface, blockouts, etc where timber/plywood formwork may be adopted. As repetitive use of forms is envisaged especially in piers, the formwork should be of firm construction to avail of the maximum reuse. Considering the speed and risks associated with the construction of works in river bed, the main criteria for forms should be the functional requirements namely, concrete strength, the appearance, tolerances, etc and these should be decided to suit the site conditions.

8.1.2 Oiling of the Formwork

Nonstaining form oil should be used for exposed surfaces. For buried surfaces waste-oil available at site may be made use of.

8.1.3 Handling of Formwork

Forms should be either handled manually or by means of machines depending on the mass of panels.

8.2 Reinforcement

All the reinforcement laid down should be in accordance with IS 456 : 1978. However, reinforcement around sill beam grooves should not be omitted. Chair support, spacers etc, should be provided as a part of reinforcement for

proper positioning of reinforcement. In case of raft foundation having two layers of reinforcement, the bottom layer would be laid first and concreting done up to appropriate levels. Chair supports are to be embedded in the last lift. The top reinforcement would then be laid and concreting done.

8.3 Curing

Curing of concrete should be done in accordance with IS 456 : 1978.

8.4 Joints

For all construction joints, the normal methods of clean-up and surface treatment should be adopted. In the rubber seals, specified formworks should be provided to support the rubber seals. Concrete in the vicinity of water-stops should have a slump of 75 to 103 mm to facilitate easy placement.

8.5 Downstream Protection

As the downstream inverted filter below the cement concrete blocks is very important as measure against piping, it has to be laid with due care. The gap between the cement concrete box should also be filled with pervious peastone or *BAJARI*. Wherever the downstream bed level is higher than the level of downstream cement concrete blocks protection, reverse slope not steeper than one in five may be provided and it may be ensured that some loose stone protection is provided for length of not less than 2 m in higher bed portion after the reverse slope. For handling of the precast blocks, crane gantries of suitable capacity should be used. In case of cast *in-situ* blocks, alternate blocks should be concreted or a proper pattern of concreting sequence should be established for economical use of blocks shuttering. If the cement concrete blocks on filter are cast *in-situ*, a mat of suitable thickness of dry concrete is to be placed over the filter inside shuttering and cement concrete block may be cast over this mat after 24 hours for preventing chokage of filter by sand-cement slurry leakage. The formwork should be so designed that when it is stripped off, the required gap is formed for filling in filter material.

9 MISCELLANEOUS

9.1 Instrumentation and operation of barrages should be done in accordance with IS 7349 : 1974.

9.2 Observation pipes should be installed at locations indicated in the approved drawings. During the construction period care should be taken so as to ensure that the pipes do not get damaged or choked.

9.3 Grout pipes should be installed in the foundations of the floors, abutment and wing-walls at regular intervals as specified in the approved drawings. 50 mm G. I. pipes should normally be used for such purpose. The pipes should be maintained in vertical position as far as practicable and ensured that the pipes do not get choked.

9.4 Architecture

Wherever possible, the shapes of the pier ends, finish of the abutment, pier, divide walls surfaces, etc, can be modified to increase the architectural beauty of the structure. But hydraulic performance and safety should not be sacrificed.

ANNEX A

(Foreword)

INFORMATION ON DEWATERING OF SOME BARRAGES IN INDIA FOR GENERAL GUIDANCE

<i>Name of Works</i>	<i>Method of Dewatering</i>	<i>Foundation Strata</i>	<i>Maximum Number of Pumps Working/ Discharge</i>
Sone Barrage in Bihar	Well point system	Coarse sand	20 No. @ 0.10 m ³ /s capacity each
Farakka Barrage in West Bengal	-do-	Sand mixed with clay layers	50 No. @ 0.15 m ³ /s capacity each
Jangipur Barrage in West Bengal	-do-	Sandy soil	5 No. @ 0.10 m ³ /s capacity each
Ghagra Barrage in U.P.	Well point and deep well pump system	Sandy soil coarse	Max discharge 5 m ³ /s with diesel and electric pump
Sharda Barrage in U.P.	-do-	-do-	Max discharge 4.50 m ³ /s with mainly deep well electric pumps
Shah Nehar Barrage in Punjab	Pumping from sumps made around the pit and supplemented by few deep well pumps	Sand, gravel and boulder	Total seepage discharge of 3 to 5 m ³ /s

ANNEX B

(Foreword)

INFORMATION ON SHEET PILING FOR GENERAL GUIDANCE

<i>Depth of Sheet Piles</i>	<i>Strata</i>	<i>Capacity of Hammer in tonnes</i>	<i>Type of Machines</i>
0 to 8 m	Sandy soil	3	Vibro-sinker 55 kW capacity
8 to 11 m	-do-	3 to 4	Initial 8 m by Vibro-sinkers and final
11 to 14 m	-do-	6 single acting	Driving by single acting drop hammers

ANNEX C

(Clause 2)

LIST OF REFERRED INDIAN STANDARDS

<i>IS No.</i>	<i>Title</i>	<i>IS No.</i>	<i>Title</i>
456 : 1978	Code of practice for plain and reinforced concrete (<i>third revision</i>)	6966 (Part 1) : 1989	Guidelines for hydraulic design of barrages and weirs: Part 1 Alluvial reaches (<i>first revision</i>)
1191 : 1971	Glossary of terms and symbols used in connection with the measurement of liquid flow with a free surface (<i>first revision</i>)	7349 : 1989	Guidelines for operation and maintenance of barrages and weirs (<i>first revision</i>)
4410 (Part 3) : 1988	Glossary of terms relating to river valley projects: Part 3 River and river training (<i>first revision</i>)	9759 : 1981	Guidelines for dewatering during construction
4410 (Part 8) : 1968	Glossary of terms relating to river valley projects: Part 8 Dams and dam Sections (<i>first revision</i>)	9795 (Part 1) : 1987	Guidelines for the choice of the type of diversion works: Part 1 Cofferdams
		10084 (Part 1) : 1982	Criteria for design of diversion works: Part 1 Cofferdams
		11130 : 1984	Criteria for structural design of barrages and weirs

Standard Mark

The use of the Standard Mark is governed by the provisions of the *Bureau of Indian Standards Act, 1986* and the Rules and Regulations made thereunder. The Standard Mark on products covered by an Indian Standard conveys the assurance that they have been produced to comply with the requirements of that standard under a well defined system of inspection, testing and quality control which is devised and supervised by BIS and operated by the producer. Standard marked products are also continuously checked by BIS for conformity to that standard as a further safeguard. Details of conditions under which a licence for the use of the Standard Mark may be granted to manufacturers or producers may be obtained from the Bureau of Indian Standards.

Bureau of Indian Standards

BIS is a statutory institution established under the *Bureau of Indian Standards Act, 1986* to promote harmonious development of the activities of standardization, marking and quality certification of goods and attending to connected matters in the country.

Copyright

BIS has the copyright of all its publications. No part of these publications may be reproduced in any form without the prior permission in writing of BIS. This does not preclude the free use, in the course of implementing the standard, of necessary details, such as symbols and sizes, type or grade designations. Enquiries relating to copyright be addressed to the Director (Publications), BIS.

Review of Indian Standards

Amendments are issued to standards as the need arises on the basis of comments. Standards are also reviewed periodically; a standard along with amendments is reaffirmed when such review indicates that no changes are needed; if the review indicates that changes are needed, it is taken up for revision. Users of Indian Standards should ascertain that they are in possession of the latest amendments or edition by referring to the latest issue of 'BIS Handbook' and 'Standards Monthly Additions'. Comments on this Indian Standard may be sent to BIS giving the following reference:

Doc No. RVD 20 (59)

Amendments Issued Since Publication

Amend No.	Date of Issue	Text Affected

BUREAU OF INDIAN STANDARDS

Headquarters:

Manak Bhavan, 9 Bahadur Shah Zafar Marg, New Delhi 110002
Telephones : 331 01 31, 331 13 75

Telegrams : Manaksanstha
(Common to all offices)

Regional Offices :

Central : Manak Bhavan, 9 Bahadur Shah Zafar Marg
NEW DELHI 110002

Telephone

{ 331 01 31
{ 331 13 75

Eastern : 1/14 C. I. T. Scheme VII M, V. I. P. Road, Maniktola
CALCUTTA 700054

{ 37 84 99, 37 85 61
{ 37 86 26, 37 86 62

Northern : SCO 445-446, Sector 35-C, CHANDIGARH 160036

{ 53 38 43, 53 16 40
{ 53 23 84

Southern : C. I. T. Campus, IV Cross Road, MADRAS 600113

{ 235 02 16, 235 04 42
{ 235 15 19, 235 23 15

Western : Manakalaya, E9 MIDC, Marol, Andheri (East)
BOMBAY 400093

{ 632 92 95, 632 78 58
{ 632 78 91, 632 78 92

Branches : AHMADABAD. BANGALORE. BHOPAL. BHUBANESHWAR.
COIMBATORE. FARIDABAD. GHAZIABAD. GUWAHATI. HYDERABAD.
JAIPUR. KANPUR. LUCKNOW. PATNA. THIRUVANANTHAPURAM.