

इंटरनेट

मानक

Disclosure to Promote the Right To Information

Whereas the Parliament of India has set out to provide a practical regime of right to information for citizens to secure access to information under the control of public authorities, in order to promote transparency and accountability in the working of every public authority, and whereas the attached publication of the Bureau of Indian Standards is of particular interest to the public, particularly disadvantaged communities and those engaged in the pursuit of education and knowledge, the attached public safety standard is made available to promote the timely dissemination of this information in an accurate manner to the public.

“जानने का अधिकार, जीने का अधिकार”

Mazdoor Kisan Shakti Sangathan

“The Right to Information, The Right to Live”

“पुराने को छोड़ नये के तरफ”

Jawaharlal Nehru

“Step Out From the Old to the New”

IS 11130 (1984): Criteria for Structural Design of Barrages and Weirs [WRD 22: River Training and Diversion Works]



“ज्ञान से एक नये भारत का निर्माण”

Satyanarayan Gangaram Pitroda

“Invent a New India Using Knowledge”



“ज्ञान एक ऐसा खजाना है जो कभी चुराया नहीं जा सकता है”

Bhartrhari—Nitiśatakam

“Knowledge is such a treasure which cannot be stolen”

BLANK PAGE



IS : 11130 - 1984

Indian Standard

CRITERIA FOR STRUCTURAL DESIGN OF
BARRAGES AND WEIRS

UDC 627.82+627.43 : 624.04

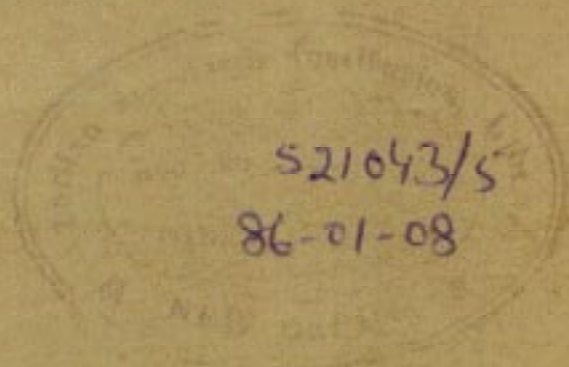

© Copyright 1985

INDIAN STANDARDS INSTITUTION
MANAK BHAVAN, 9 BAHADUR SHAH ZAFAR MARG
NEW DELHI 110002

Indian Standard

CRITERIA FOR STRUCTURAL DESIGN OF BARRAGES AND WEIRS

Barrages and Weirs Sectional Committee, BDC 65

Chairman

SHRI S. M. DEB

Representing

Irrigation and Waterways Directorate, Government of West Bengal, Calcutta

Members

SHRI N. K. ARORA

SHRI R. M. JOLLEY (*Alternate*)

SHRI L. S. BASSI

Bhakra Beas Management Board, Nangal

Ministry of Shipping and Transport (Roads Wing), New Delhi

SHRI M. K. MUKHERJEE (*Alternate*)

SHRI D. N. BHARGAVA

SHRI A. S. RAJPUT (*Alternate*)

SHRI S. N. BISWAS

CHIEF ENGINEER (M. H. P. D.)

DIRECTOR (H. W.) (*Alternate*)

DIRECTOR

Irrigation Research Institute, Roorkee

Irrigation Department, Government of Bihar
Irrigation Works, Government of Punjab, Chandigarh

Irrigation Department, Government of Madhya Pradesh, Bhopal

SHRI H. K. KHOSLA

Irrigation Department, Government of Haryana, Chandigarh

SUPERINTENDING ENGINEER (*Alternate*)

SHRI J. A. MURRAY

Irrigation and Power Department, Government of Andhra Pradesh, Hyderabad

DR J. PURUSHOTTAM (*Alternate*)

SHRI N. NARAYANAN

DEPUTY DIRECTOR (B & CD-I) (*Alternate*)

SHRI B. K. RAO

SHRI R. C. KATHORIA (*Alternate*)

SHRI P. C. SAXENA

SHRI N. V. PRAHLAD (*Alternate*)

SHRI K. T. SUBUDHI

Central Water Commission, New Delhi

Public Works Department, Government of Gujarat

Central Water and Power Research Station, Pune

Irrigation and Power Department, Government of Orissa, Bhubaneswar

SHRI S. N. SINHA (*Alternate*)

(Continued on page 2)

© Copyright 1985

INDIAN STANDARDS INSTITUTION

This publication is protected under the *Indian Copyright Act (XIV of 1957)* and reproduction in whole or in part by any means except with written permission of the publisher shall be deemed to be an infringement of copyright under the said Act.

(Continued from page 1)

Members

SUPERINTENDING ENGINEER
(BARRAGES)

SHRI A. N. N. SWAMI

SHRI K. M. KULKARNI (*Alternate*)

SHRI V. VENKATASWARALU

SHRI A. K. MEHTA (*Alternate*)

SHRI G. RAMAN,
Director (Civ Engg)

Representing

Irrigation Department, Government of Uttar
Pradesh, Lucknow

The Hindustan Construction Co Ltd, Bombay

National Projects Construction Corporation Ltd,
New Delhi

Director General, ISI (*Ex-officio Member*)

Secretary

SHRI HEMANT KUMAR

Assistant Director (Civ Engg), ISI

Indian Standard

CRITERIA FOR STRUCTURAL DESIGN OF BARRAGES AND WEIRS

0. FOREWORD

0.1 This Indian Standard was adopted by the Indian Standards Institution on 31 July 1984, after the draft finalized by the Barrages and Weirs Sectional Committee had been approved by the Civil Engineering Division Council.

0.2 Barrages and weirs are constructed for diverting water from rivers for various uses like irrigation, navigation, power generation and drinking/industrial water supply. The structure may be either of masonry or plain concrete or reinforced concrete, depending on the nature of foundation encountered, availability of construction materials, dewatering problems, economy of construction, etc. Once the selection of the type of structure is made the various components of the structure have to be very carefully designed for ensuring both safety and economy.

0.3 Depending on the types of foundation materials encountered, some foundation treatments may become necessary. These will have to be properly evolved and their effect taken into consideration while designing the structure. The type of cut-offs proposed will have to be suitably selected depending on the construction difficulties and these will have to be carefully designed to ensure safety of the structure.

0.4 The barrage or weir structures consist of essential components such as cut-offs, floor, piers, divide walls, energy dissipation arrangement, flexible protection works, abutments, flank walls, flared walls, gates or falling shutters, stoplogs, hoists and hoist bridges, trestles, guide bunds, afflux bunds, tie bunds, head regulators, silt excluder, fish ladder, and road/railway bridge. However, one or more of these components may be omitted depending on the site conditions and requirements.

0.5 This standard is one of a group of standards covering the design criteria and general features of barrages and weirs. The other four standards already published are IS : 6966-1973*, IS : 7349-1974†, IS : 7720-1975‡ and IS : 8408-1976§.

*Criteria for hydraulic design of barrages and weirs.

†Code of practice for operation and maintenance of barrages and weirs.

‡Criteria for investigation, planning and layout for barrages and weirs.

§Criteria for river training works for barrages and weirs in alluvium.

0.6 For the purpose of deciding whether a particular requirement of this standard is complied with, the final value, observed or calculated, expressing the result of a test or analysis, shall be rounded off in accordance with IS : 2-1960*. The number of significant places retained in the rounded off value should be the same as that of the specified value in this standard.

1. SCOPE

1.1 This standard covers the criteria for the structural design of barrages and weirs.

2. TERMINOLOGY

2.0 For the purpose of this standard, the following definitions and those given in IS : 4410 (Part 3)-1967†, IS : 4410 (Part 5)-1968‡ and IS : 6966-1973§ shall apply.

2.1 **Block-Outs** — Temporary recesses provided in the civil structure to facilitate proper embedment of steel fixtures or gates, trestles, etc, and which are concreted after their fixing.

2.2 **Chute Blocks** — Staggered R.C.C. blocks provided at the toe of the downstream glacis for energy dissipation.

2.3 **Cut-Offs** — Barriers either of R.C.C. masonry or of steel sheet pile, provided at the bottom of the structure to protect the structure against scours and possible piping due to excessive exit gradients of the seepage flow below the foundations.

2.4 **Divide Wall** — Wall constructed usually at right angles to the axis of the barrage or weir generally extending beyond the main structure to separate the under sluices, river sluices and spillways into independent units for facilitating regulation.

2.5 **End Sill** — A vertical, stepped, sloped or dentated wall constructed at the downstream end of the stilling basin.

2.6 **Fish Ladder/Lock** — Device provided in the diversion structure preferably adjacent to the divide wall to facilitate the passage of fish from upstream to downstream and *vice versa*. In the fish ladder, the difference

*Rules for rounding off numerical values (*revised*).

†Glossary of terms relating to river valley projects : Part 3 River and river training.

‡Glossary of terms relating to river valley projects : Part 5 Canals.

§Criteria for hydraulic design of barrages and weirs.

in the water levels between the upstream and downstream of the structure is split up into several steps by means of a series of baffle walls to enable the fish to negotiate it. In the fish lock, the passage of the fish from upstream to downstream and *vice versa* is ensured by the operation of the lock and its gates periodically.

2.7 Friction Blocks — Staggered blocks provided in the stilling basin for energy dissipation.

2.8 Glacis — The sloping portion of the floor upstream and downstream of the crest.

2.9 Modulus of Subgrade Reaction (K_s) — It is the ratio of load per unit area (applied through a centrally-loaded rigid body) of horizontal surface of a mass of soil to corresponding settlement of the surface.

2.10 River Sluices — A set of sluices similar to the under sluices located in between the under sluice and spillway bays and separated from them by means of divide walls. These are provided in long structures to simplify the operation of gates during normal floods and have better control on the river.

2.11 Silt Excluder — A device by which silt is precluded from entering the canal.

2.12 Stoplogs — Fabricated structural steel or wooden units utilised for temporary closure of any bay in order to facilitate repairs of the gate and other components of the bay.

3. DATA REQUIRED

3.1 In addition to the data listed in IS : 7720-1975* and IS : 6966-1973† and the analysed values thereof, the following data is required to be collected:

- a) High flood and minimum water level in the river.
- b) Design pond level.
- c) The lowest and highest tide levels in case of tidal streams.
- d) Intensity of silt charge in the river during high and low flood stages.
- e) Log of drill holes to a depth of at least 10 m at a spacing of 20 to 25 m at least in three rows. One row of boreholes may be along the barrage/weir axis, the second row at a distance of about 15 m upstream of the axis and the third row at a distance of about 15 m upstream of the axis and the third row at a distance of

*Criteria for investigation, planning and layout for barrages and weirs.

†Criteria for hydraulic design of barrages and weirs.

about 30 to 40 m downstream of the axis. The location of boreholes along the barrage/weir axis shall be staggered with reference to those along the upstream and downstream lines. However, these are essential wherever presence of clay stratum is detected in the foundation. The extent, depth and location of the clay layer should be correctly assessed.

- f) In sandy strata, standard penetration test results for a depth of at least 8 to 12 m at a spacing of 40 to 50 m in the transverse direction (along the river width) and at a spacing of 30 m in the longitudinal direction (along the flow). For details of standard penetration test, reference may be made to IS : 2131-1963*.
- g) Wherever clayey strata is encountered, undisturbed samples of the clay layers from the proposed foundation level or up to 8 m or more depending upon the each individual situation below the foundation level for each day. These samples should be analysed to determine the shear parameters, void ratio consolidation characteristics, moisture content, *in-situ* density, sensitivity and permeability.
- h) For sandy soil, grain size distribution curves from undisturbed samples obtained at 3 m intervals for each bore hole [see IS: 2720 (Part 4)-1975†]. Dry densities, relative densities and angle of internal friction should be obtained.
- j) Modulus of subgrade reaction at the proposed foundation level. This value shall be obtained by conducting *in-situ* tests conforming to IS : 1888-1982‡ if the floor of the barrage is to be designed as an R.C.C. raft supported on elastic medium; if the structure is long or there is wide variation in the properties of the foundation materials, the length of the structure shall be split up into suitable units isolated from each other by means of double piers and the values of modulus of subgrade reaction shall be determined in every bay. The double piers shall be provided suitably to isolate such units for independent action.

NOTE — If it is not feasible to determine the modulus of subgrade reaction at site, the values given in Appendix D of IS : 2950 (Part 1) - 1973§ may be adopted for design purposes, depending on the type of soil.

- k) 1) Type and size of gates and stop log gates (if any), their mass, including that of hoisting arrangement.
- 2) Details of block-outs for gate grooves, sill beams and foundations of stanchions including the section through gate groove.

*Method of standard penetration test for soils.

†Methods of test for soils: Part 4 Grain size analysis (*first revision*).

‡Method of load tests on soils.

§Code of practice for design and construction of raft foundation: Part 1 Design.

- m) Type of bridge, width of roadway, foot-path, and class of loading.
- n) Results of model studies.
- p) Stage-discharge curve at site up to high flood level.

4. MATERIALS

4.1 Concrete — Unless otherwise specified, controlled concrete mix conforming to IS : 456-1978* shall be used for the construction.

4.2 Masonry — Wherever masonry is adopted, such as flared out wall, impervious floor, pier, etc, masonry shall conform to IS : 1597 (Part 1)-1967†.

4.3 Steel — Steel used for reinforcement bars shall conform to IS : 432 (Part 1)-1982‡ or IS : 1139-1966§ or IS : 1786-1979||.

4.4 Structural Steel — Structural steel of standard quality of fusion welding quality used for different components shall comply with the requirements given in IS : 226-1975¶ and IS : 2062-1969**.

5. DESIGN CRITERIA

5.1 The design criteria given in 5.2 to 5.11.3.3 is generally considered as guidelines and may be modified to suit the field conditions with due consideration for safety and economy. R.C.C. work shall be done in accordance with IS : 456-1978*.

5.2 Cut-Offs

5.2.1 The upstream and downstream cut-offs of the diversion structure may be of steel sheet piles anchored to the barrage/weir by means of R.C.C. caps, or of masonry or reinforced cement concrete or R.C.C. diaphragm wall. The depth of cut-off shall be fixed in accordance with IS : 6966-1973††.

*Code of practice for plain and reinforced concrete (*third revision*).

†Code of practice for construction of stone masonry: Part 1 Rubble stone masonry.

‡Specification for mild steel and medium tensile steel bars and hard-drawn steel wire for concrete reinforcement: Part 1 Mild steel and medium tensile steel bars (*second revision*).

§Specification for hot rolled mild steel, medium tensile steel and high yield strength deformed bars for concrete reinforcement (*revised*).

||Specification for cold-worked steel high strength deformed bars for concrete reinforcement (*second revision*).

¶Specification for structural steel standard quality (*fifth revision*).

**Specification for structural steel fusion welding quality (*fifth revision*).

††Criteria for hydraulic design of barrages and weirs.

5.2.2 The sheet pile cut-offs shall be designed as sheet pile retaining walls anchored at top. They shall be designed to resist the worst combination of forces and moments considering the possible scour on the outer side, earth pressure and surcharge due to floor loads on the inner side, differential hydrostatic pressure computed on the basis of the percentage of pressure of seepage flow below the floor, etc. In case the effect of cut-offs is taken into account for resistance against forward sliding of the structure, the cut-offs shall also be designed withstand the passive pressures developed.

5.2.2.1 The R.C.C pile caps shall be designed to transmit the forces and moments acting on the steel sheet pile cut-offs to the barrage/weirs floor.

5.2.3 The upstream and downstream masonry or R.C.C cut-offs shall be designed to resist the forces and moments specified in 5.2.2 as cantilever walls casted monolithically with the floor of the barrage/weir.

5.3 Impervious Floor

5.3.1 Following are the two types of floors:

- a) Gravity type where the uplift pressure is balanced by the self weight of the floor only considering unit length of the floor; and
- b) Reinforced cement concrete raft type where the uplift pressure is balanced by the weight of the floor, piers and other super-imposed dead loads considering a span as single unit. While the gravity type can either be of plain concrete or masonry, the raft type would be of reinforced concrete only.

5.3.2 The hydraulic design of the impervious floor shall conform to IS : 6966-1973*. The hydraulic design of the stilling basin which is also a part of the floor, shall conform to IS : 4997-1968†.

5.3.3 Thickness of Floor — Thickness of the impervious floor shall be adequate to counter balance the uplift pressure at the point under consideration (see 5.3) for gravity type and reinforced cement concrete type of floor.

5.3.3.1 Uplift Pressure — The uplift pressure at any point shall be calculated by any accepted practice taking into account the effect of the upstream and downstream cut-offs, intermediate cut-offs (if any), interference of cut-offs, thickness of floor and slope of the glacis.

*Criteria for hydraulic design of barrages and weirs.

†Criteria for design of hydraulic jump type stilling basins with horizontal and sloping apron.

5.3.3.2 Hydraulic jump — The thickness of downstream floors shall also be checked under the hydraulic jump conditions. For this purpose the gate operation chart adopted in arriving at the cistern level and its length may be made use of.

5.3.4 Gravity Floor — The thickness of the floor adopted for construction shall be at least 10 percent more than the thickness required to counteract the uplift pressure at that point under the worst possible combination of loads in different including seismic conditions.

5.3.4.1 Abutments and piers may either be independent of the floor separated from it by means of water tight seals or may be monolithic with the floor. The latter case may be adopted only if the thickness of the floor is equal to or more than half the length of one span.

5.3.4.2 Where the floor is of plain concrete, suitable temperature reinforcement shall be provided.

5.3.5 Reinforced Cement Concrete Raft

5.3.5.1 Spans up to 6 m — The design of the raft may generally be done as per the theory of beams on elastic foundation. The design will depend on the value of modulus of subgrade reaction (K), span length, total length of raft, etc. However, for small spans up to 6 m, the floor shall be designed as a continuous beam resting on a homogeneous foundation. The abutment, if necessary, may be made independent by providing a joint in the raft with suitable water seals. The raft shall be designed for the moments caused by the worst combination of the following forces:

- a) Uplift;
- b) Soil reaction;
- c) Moments transferred from the abutments and piers; and
- d) Seismic forces, if any.

For this purpose, the loads transmitted by the abutments and piers may be assumed to be distributed uniformly on the foundation. For design of rafts, reference may also be made to IS : 2950 (Part 1)-1973*.

5.3.5.2 Spans above 6 m — The floor shall be designed as a finite beam resting on elastic foundation and subjected to concentrated loads and moments at the pier and abutment points. Taking duly into account the effect of the width of the raft actually provided, the value of the modulus of subgrade reaction (K_s) shall be determined as prescribed in IS : 2950 (Part 1)-1973* and IS : 9214-1979†.

*Code of practice for design and construction of raft foundations: Part 1 Design.

†Method of determination of modulus of subgrade reaction (K -value) of soils in field.

5.3.5.3 For the purpose of analysis, the entire width of the raft may be divided into different sections, depending on the loads and moments anticipated to act over the different sections, such as upstream section (including glaxis), downstream glaxis and downstream cistern sections.

5.3.5.4 The requirement of reinforcement bars in respect of both diameter and spacing for the different sections of the raft, calculated as per provisions given in 5.3.5.1 and 5.3.5.2 shall be suitably adjusted from the view point of ease of construction. Similarly, adequate distribution reinforcement shall also be provided with the ease of construction in view. Suitable reinforcement shall be provided around the blackout holes left for the sill beams of crest gates and stoplogs.

5.4 Piers

5.4.1 In barrages and weirs constructed as a reinforced cement concrete structure, the piers are constructed monolithic with the floor of the diversion structure. However, the piers in the gravity type of floor are generally constructed independent of the floor. Proper joint and sealing arrangements between the gravity floor and the pier all around shall be provided. However, where piers are proposed to be made monolithic with the floor in the case of gravity type, provisions mentioned in 5.3.4.1 shall be complied with.

5.4.2 Thickness of Pier — The thickness of the pier shall be fixed from consideration of (i) forces and moments transferred by the pier to the floor/foundation (ii) minimum thickness required at the blockouts for the main gate and stoplog grooves and (iii) the mass of the pier required for counter-acting the uplift pressure. The thickness of the pier for reinforced cement concrete structures generally varies from 1.5 to 2.5 m.

5.4.3 Length of Pier — In the case of a raft type floor of the diversion structure, the piers shall generally be extended up to the full width of the raft to avoid cantilever action of the raft at the ends. In the case of gravity type floor, the length of pier may however, be restricted according to the minimum requirement from considerations of road rail bridges, hoist bridge, space required for housing instruments, if any, main gate grooves, stoplog grooves, space for storage of stoplogs, adequate length to prevent cross flows occurring which may cause damages to the floor and beyond.

5.4.4 Height of Pier

5.4.4.1 On the upstream side, the pier shall generally be constructed above the pond level affluxed HFL with adequate free board. The height shall also be fixed as per requirement of the mass of the pier in counter-acting uplift pressure. The height of the pier shall also be such that under fully raised position above the affluxed HFL/pond level, about one metre of the gate still remains within the gate groove.

5.4.4.2 On the downstream side, the piers shall generally be constructed at least one metre above the high flood level up to 1 to 2 m as found necessary beyond the end of the bridges and instrumentation platform, if any and thereafter the height could be reduced according to low flood levels on the downstream side. In the portions where road/rail bridges are provided, the height of the piers shall be fixed such that the bearings of the bridges are not hit by floating debris during high floods.

5.4.4.3 In the main gate portion, the height of the pier shall be fixed such that during high flood, the bottom of the gate is at least one metre clear of the affluxed high flood level. In earthquake regions, however, the top level of the pier could be restricted to the top level of the abutments and steel trestles provided over the piers for housing the hoist bridges for operation of the gates and stoplogs. This arrangement would reduce the loads and moments due to inertia during earthquake.

5.4.5 Design

5.4.5.1 General — For design of the pier, the worst combination of the following forces and moments shall be considered:

- a) Dead loads;
- b) Live loads due to road/railway bridges as in relevant Indian Roads Congress Codes;
- c) Impact due to live loads;
- d) Longitudinal forces caused by tractive efforts of vehicles or by braking of vehicles and/or those caused by restraint of movement of free bearings by friction or deformation;
- e) Temperature forces transmitted through bridge bearings;
- f) Dead and live loads of gates, stoplogs counter weights and the hoist bridge;
- g) Braking effect of gantry crane;
- h) Buoyancy;
- j) Wind forces;
- k) Water current forces;
- m) Differential hydrostatic pressure with one side gate open and the other adjacent gate closed;
- n) Seismic forces and movements, if any; and
- p) Hydrodynamic forces due to seismic conditions, if any.

Apart from above, the other forces shall be as specified in relevant Indian Roads Congress Bridge Codes available.

5.4.5.2 For checking the stability, two emergency conditions (like high flood level and seismic) shall not be combined together. Similarly wind forces may not be considered while taking seismic forces.

5.4.5.3 The reinforcement of the pier could be curtailed at convenient levels keeping in view the requirements calculated as given in 5.4.5.1. The reinforcement shall be adequately taken into the raft/foundation slab as the case may be and anchored properly.

5.4.5.4 *Blockout zones* — For design of blockouts, the following points shall be kept in view:

- a) The width of the pier between the blockouts on either face shall not be less than 60 cm.
- b) The increase in the sectional area of the pier in the blockout zone due to the second stage concrete shall be ignored while calculating the reinforcement.
- c) Blockout zones shall be designed to withstand the concentration of stresses due to the worst combination of forces and moments listed in 5.4.5.1 and differential hydrostatic pressure with the gate closed on one side and stoplogs dropped on the other adjacent side.
- d) Adequate dowel bars and secondary reinforcement shall be provided in the second stage concrete to effectively bond it to the main pier concrete.

5.4.6 *Double Piers*

5.4.6.1 Depending on the variation in the foundation characteristics, construction programme and design considerations of the raft, the waterway of the barrage/weir is split up into different units. Each unit comprises a number of bays, ranging usually from 5 to 10. Between each unit, double pier shall be provided with proper joint and sealing arrangement. Each unit shall be thoroughly boxed at the foundation by the upstream and downstream sheet piles/cut-offs and cross sheet piles/cut-offs below the double piers. The depth of cross sheet piles/cut-offs shall be suitably varied from the upstream sheet pile/cut-off level to the downstream sheet pile/cut-off level.

5.4.6.2 *Thickness of pier* — The thickness of the double pier for R.C.C structures generally varies from 3 to 5 m. The thickness is governed by the considerations specified for single pier in 5.4.2.

5.4.6.3 *Length of pier* — The length of the double pier is governed by the considerations specified for single pier in 5.4.3.

5.4.6.4 *Height of pier* — The height of the double pier is governed by the considerations specified for single pier in 5.4.4.

5.4.6.5 Design — Each unit of the double pier shall be structurally independent of the other without any transfer of loads and moments from one to the other. The design criteria specified for single pier in 5.4.5 shall hold good for the design of double pier also. For this purpose, each unit of the double pier shall be treated as acting completely independent of the other pier.

5.4.7 Pier Cap

5.4.7.1 Properly designed pier caps shall be provided under the bridges. Their broad features shall satisfy aesthetic requirements also.

5.4.7.2 Thickness — The thickness of the pier cap shall not be less than 300 mm for spans up to 25 m.

5.4.7.3 Reinforcement — The reinforcement for the pier cap should be distributed both at top and bottom in the longitudinal and transverse directions. In addition to this, two layers of mesh reinforcement of 6 mm diameter spaced at 75 mm centre to centre shall be placed under the bearings of the road/rail bridge beams.

5.5 Divide Walls — Undersluice, river sluice, and spillway bays of the barrage/weir are separated by divide walls. These extend both upstream and downstream generally beyond the barrage/weir floor. In some cases, the downstream portion of the divide wall beyond the requirement of pier is omitted if so indicated by hydraulic model tests. The main functions of the divide walls are explained in IS : 7720-1975*.

5.5.1 Position and Length of Divide Walls — For fixing preliminary dimensions of the divide walls for the purposes of hydraulic model tests, the position and length of divide wall may be fixed as laid down in 3.7 of IS : 7720-1975*. Final layout and exact length of the divide walls shall, however, be determined on the basis of hydraulic model studies to ensure adequacy of tail water depth in the undersluice and river sluice bays for the formation of hydraulic jump and to avoid cross flow in the close vicinity of the structure which may result in objectionable scours on the downstream side.

5.5.2 Foundation

5.5.2.1 The foundation of the divide walls shall be extended below the bed up to a depth of $2.25R$ below the high flood level at the nose portion with adequate grip lengths where R is the calculated Lacey's depth of scour below high flood level. The depth of foundation may be decreased progressively towards the *pucca* floor of the barrage/weir up to a minimum depth of main cut-offs provided.

*Criteria for investigation, planning and layout for barrages and weirs.

NOTE — For calculation of the value of R , reference may be made to IS : 6966-1973*.

5.5.2.2 The foundation of the divide walls shall be made of steel sheet piles in portions, wherever it is possible to drive the sheet piles of sufficient depths and in other portions, it shall be made of walls (see Fig. 1). For design of well foundation, reference may be made to IS : 3955-1967†.

5.5.2.3 The upstream and downstream divide walls shall be separated out from the main pier beyond the *pucca* floor of the barrage/weir by joints. Joints shall also be provided in the divide walls at places where there are changes from sheet pile/cut-off foundation to well foundation.

5.5.3 Height — The top levels of the divide walls shall be fixed above the the high flood levels with sufficient free board.

5.5.4 Design

5.5.4.1 The upstream divide wall shall be designed to resist the differential head on account of the velocity of flow in the pocket due to the gates adjacent to the divide wall on either side being kept in open and closed condition. The downstream divide wall shall be designed to resist the moments due to the differential head caused by the closure of gate on one side and opening of gate on the other side. The differential heads to be considered in the design are indicated by hydraulic model tests wherever conducted. However, for preliminary designs, a differential head of about 2 m may be assumed.

5.5.4.2 Under seismic conditions, differential head due to wave action need not be considered as the likelihood of earthquake and high wind occurring simultaneously is rather remote. Dynamic increase in water pressure shall be considered as given by the formula,

$$p = 89 \alpha_h \sqrt{Hy}$$

where

p = hydrodynamic pressure in N/m^2 ,

α_h = design horizontal seismic coefficient,

H = height of water surface from the level of deepest scour in metres, and

y = depth of the section below the water surface in metres.

NOTE — For more details, reference may be made to IS : 1893-1975‡.

*Criteria for hydraulic design of barrages and weirs.

†Code of practice for design and construction of well foundations.

‡Criteria for earthquake resistant design of structures (*third revision*).

5.5.4.3 The divide walls shall be checked for their overall stability. Forces due to self weight, water (including ice wherever applicable), uplift, etc, shall be considered alongwith earthquake forces acting on the walls. While checking the stability, two emergency conditions (like HFL and seismic) shall not be combined together.

5.6 Abutments — Abutments are generally designed as retaining walls separated from the main floor by an expansion joint settlement joint with seals. In some cases, if the total waterway between the abutments does not exceed 40 to 50 m, the abutments are constructed monolithic with the main floor and the whole section is designed as a trough. For analysis and design, along the flow direction, the abutments are generally divided into three to four blocks, namely, upstream block, gate bridge block, road/rail bridge block and downstream block, depending on the loadings. The blocks are usually separated by joints with seals and designed properly to resist the loads and moments acting on the blocks (see Fig. 2).

5.6.1 Top Width — Top width of the abutment in each block shall be fixed as per the requirements due to the loads and moments, minimum width required for block-outs of main gate and stoplog grooves, bridge bearings, gate trestle foundation, etc. Minimum width of abutment clear of the block-outs and behind bearing niches shall be 60 cm.

NOTE — The minimum top width of abutment of the upstream and downstream blocks is generally kept as 60 cm. In the gate and road/rail bridge block, it is generally kept as 125 to 140 cm.

5.6.2 Fillet — It is desirable to provide 30 cm × 30 cm to 45 cm × 45 cm fillet at the junction of the vertical stem with the heel of the base slab and adequately reinforced.

5.6.3 Design

5.6.3.1 For design of the abutment blocks, worst combination of the following forces and moments, pertaining to the block under consideration, shall be taken into account:

- a) Dead load;
- b) Live load due to moving traffic over the bridges;
- c) Impact due to live loads;
- d) Longitudinal forces caused by tractive efforts of vehicles or by braking of vehicles and/or these caused by restraint of movement of free bearings by friction or deformation;
- e) Dead and live loads of gate and gate bridge;
- f) Braking effect of gantry crane;
- g) Earth pressure, live load surcharge and saturation pressure;

- h) Uplift;
- j) Wind forces;
- k) Water current forces;
- m) Seismic forces and moments, if any; and
- n) Hydrodynamic forces due to seismic conditions, if any.

Apart from above, the other forces shall be as specified in relevant Indian Roads Congress Bridge Codes available.

5.6.3.2 For checking the stability, two emergency conditions (like *HFL* and seismic) shall not be combined together. Similarly wind forces may not be considered while taking earthquake forces.

5.6.3.3 The abutment section shall be checked for safety against allowable bearing pressure, overturning and sliding.

5.6.3.4 Allowable bearing pressure shall be determined by field and laboratory tests. Reference may be made to the relevant Indian Standards.

5.6.3.5 The factor of safety against overturning shall not be less than 2.00 under normal conditions of loading and not less than 1.5 under seismic conditions of loading.

5.6.3.6 The factor of safety against sliding shall not be less than 1.75 under normal conditions of loading and not less than 1.5 under seismic conditions of loading.

NOTE — For calculation of the loads and moments due to earthquake, reference may be made to IS : 1893-1975*. For calculation of the overturning and sliding factors, reference may be made to IS : 1904-1977†.

5.6.3.7 The value of the co-efficient of friction shall be determined by field investigations. However, in cases where this is not possible, the values given below can be adopted for designs:

<i>Material</i>	<i>Co-efficient of Friction</i>
Soft clay, silt	0.25
Medium of stiff clay	0.30
Silty sand, sand and gravel with high clay content	0.35
Coarse sandy soil containing silt	0.45
Coarse sandy soil containing no silt or clay	0.55

*Criteria for earthquake resistant design of structures (*third revision*).

†Code of practice for structural safety of buildings — Shallow foundation (*second revision*).

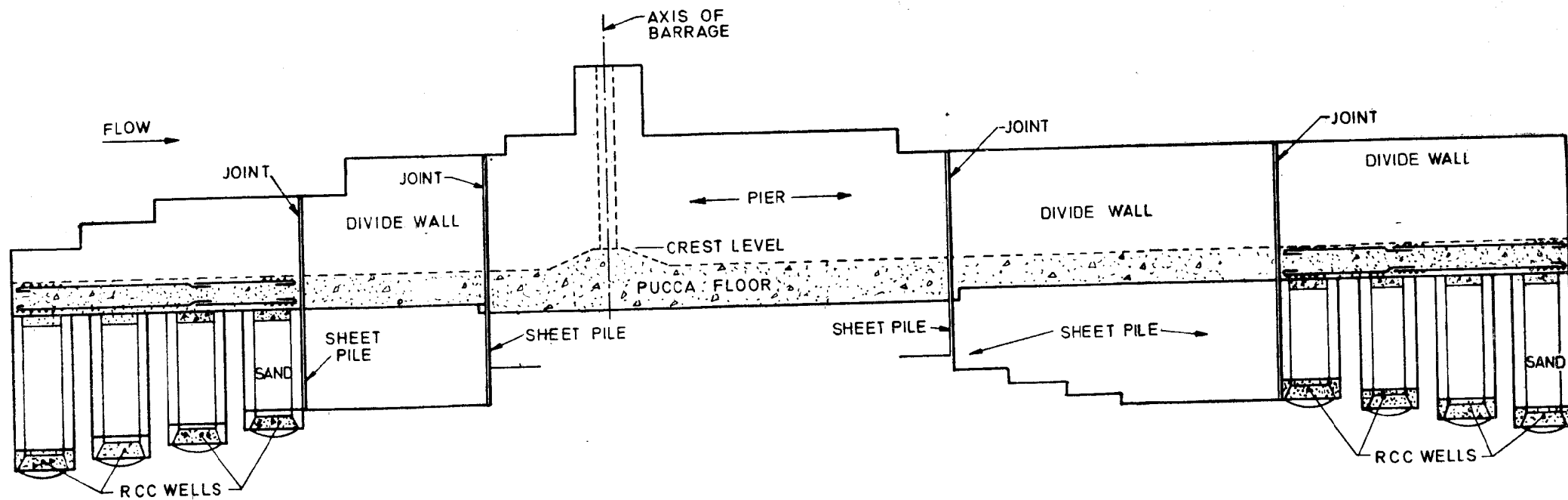

All dimensions in millimetres.

FIG. 1 TYPICAL DETAILS OF FOUNDATION FOR DIVIDE WALLS

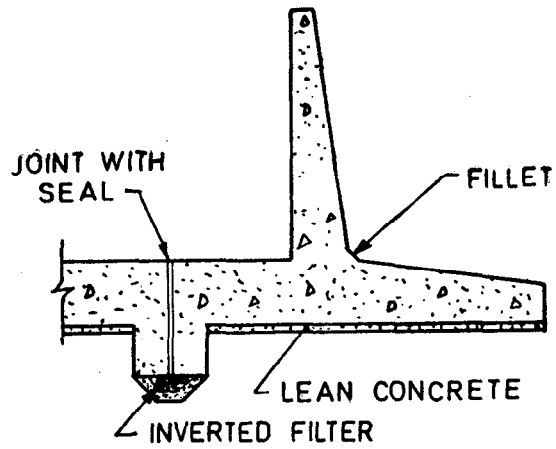

(2A)

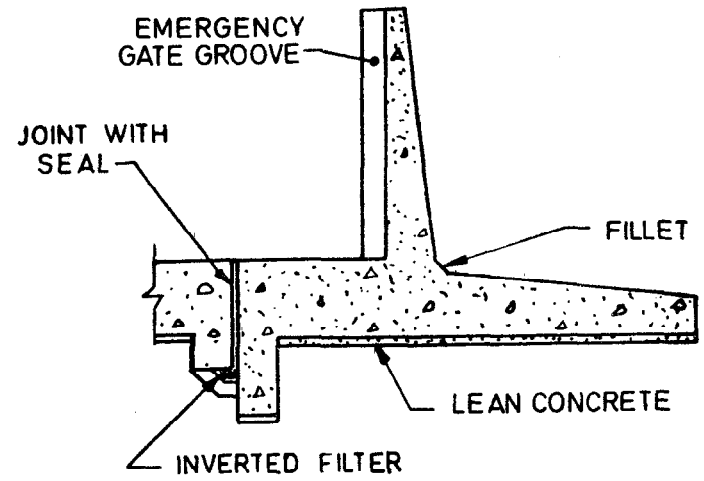

(2B)

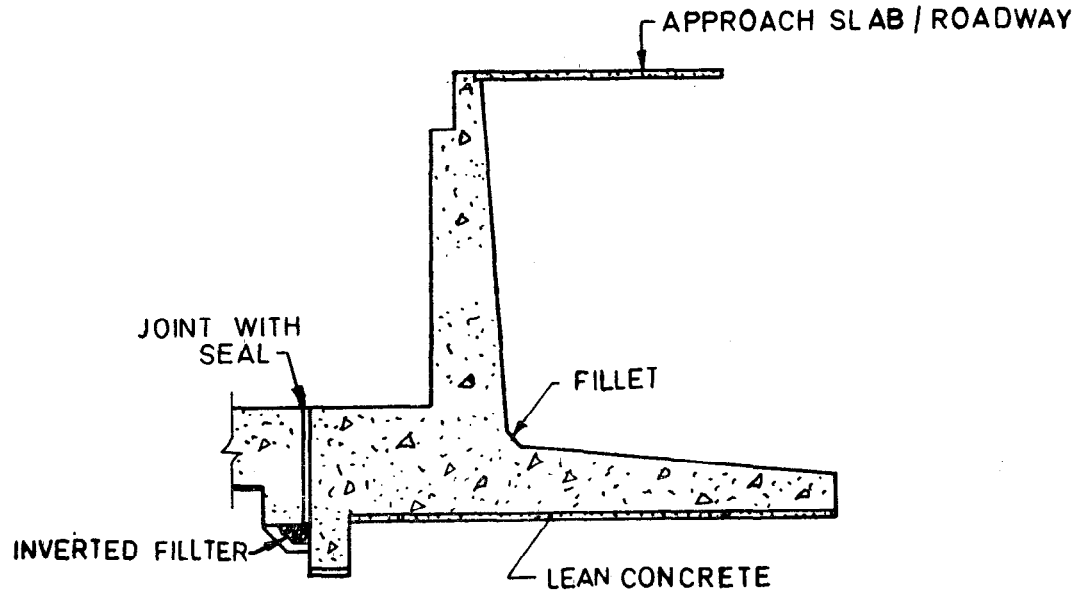

(2C)

All dimensions in millimeters.
FIG. 2 TYPICAL SECTIONS OF ABUTMENT

5.6.3.8 Wherever concrete/masonry or sheetpile cut-offs have been provided, 50 percent of the passive pressure developed below the level of the deepest scour may be considered to the extent of the structural strength of the cut-off provided while calculating the counteracting forces against sliding.

5.7 Flank Wall — In continuation of abutments of the weir/barrage head regulators, flank walls are provided both on the upstream and downstream sides on both the banks. However, if site conditions permit, one or more of these flank walls may be omitted and the banks may be trimmed and adequately pitched with stones. The flank walls ensure smooth entry and exit of waters into and away from the barrage/weir. On the upstream side, the flank wall may be provided a transition from the slope of the guide bund to vertical face at the abutment and over a length of 2 to 2.5 L_1 , where L_1 , is the sloping length of the water face of the u/s guide bund (see Fig. 4). On the downstream side, this transition may be provided over a length of 2.5 to 3.5 L_2 , where L_2 is the sloping length of the water face of the d/s guide bund. The total transition length is made up of two types of construction, one with solid concrete/masonry wall usually called to flank wall and the other with concrete/masonry and cement concrete blocks, usually called the flared out wall. The waterface of the flank wall (solid wall portion) is generally changed from vertical at the abutment end to a slope of 0.5 (horizontal) : 1 (vertical) and the stem is constructed of concrete/masonry throughout its height. The waterface of the flared out wall is generally changed from the slope of the end section of flank wall (generally 0.5 : 1) to the slope of the guide bunds which is generally 2:1 to 3:1. The stem of the flared out wall is constructed of concrete/masonry for certain height, overlaid by interlocking cement concrete blocks one above the other. The number of interlocking cement concrete blocks varies as the slope of the flared out wall varies (see Fig. 2).

5.7.1 Top Width

5.7.1.1 The top width of the flank wall shall not be less than 600 mm.

5.7.1.2 The top width of the flared out wall would be varying depending on the size of the cement concrete block. Generally a size of 1 500 mm is adopted (see Fig. 3).

5.7.2 Fillet — It is desirable to provide 30 cm × 30 cm to 45 cm × 45 cm fillet at the junction of the stem of the flank wall (solid concrete/masonry wall) with the heel of the base slab and adequately reinforced.

5.7.3 Design

5.7.3.1 For the design of the flank wall and flared out wall as an earth

retaining structure, worst combination of the following forces and moments shall be taken into account:

- a) Dead loads;
- b) Earth pressure, live load surcharge and saturation pressures;
- c) Uplift;
- d) Seismic forces and moments, if any; and
- e) Hydrodynamic forces due to seismic condition if any. For checking the stability, two emergency conditions (like *HFL* and seismic) shall not be combined together.

5.7.3.2 The flank wall and flared out wall sections shall be checked for safety against allowable bearing pressure, over turning and sliding as in the case of abutment. For calculation of earth pressures, any standard practice may be adopted.

5.8 Return Wall

5.8.1 Return walls are generally provided at right angles to the abutment either at its ends or at the flank wall portion (see Fig.3). Wherever return walls are constructed as part of the flank wall, it is desirable to separate the stem of the return wall from the stem of the flank wall by a joint. The base slab for the flank wall and return wall would be the same and shall be designed carefully to resist the loads and moments acting on the same.

5.8.2 Top Width — The top width of the return wall shall not be less than 600 mm.

5.8.3 Fillet — It is desirable to provide 30 cm × 30 cm to 450 cm × 450 cm fillet at the junction of the stem of the return wall with the heel of the base slab and adequately reinforced.

5.8.4 Length — Where the return-walls are provided at the ends of the abutment, they shall be extended at least up to the end of the heel portion of the base slab of upstream or downstream abutment blocks as the case may be. In the case of the head regulator, the return-walls shall be keyed properly into the embankment of the canal for a length of at least 2 m beyond the top edge. Where the return wall is part of the flank wall, the same shall be extended up to the end of the heel portion of the base slab.

5.8.5 Design

5.8.5.1 For design of the return wall, worst combination of the following forces and moments shall be taken into account:

- a) Dead loads;
- b) Earth pressure, live load surcharge and saturation pressures;

- c) Uplift;
- d) Seismic forces and moments, if any; and
- e) Hydrodynamic forces.

For checking the stability, two emergency conditions (like *HFL* and seismic) shall not be combined together.

5.9 Silt Excluder

5.9.1 Silt excluder tunnels either of the kala bagh type or khanki type are generally provided in the form of rectangular R.C.C barrels. The number of undersluice bays and the number of silt excluder tunnels in each bay to be provided, their location, layout and dimensions shall be fixed on the basis of model tests in order to obtain optimum silt exclusion from the waters entering into the head regulator (see Fig. 4).

5.9.2 Design

5.9.2.1 For the design of silt excluders, the following loads shall be considered:

- a) Load due to water of the pond, and
- b) Load due to silt deposited.

5.9.2.2 The silt excluder tunnels shall be designed for the worst combination of loadings and moments with one or more tunnels considered empty at a time and all vertical loads including the load of water inside the other tunnels.

5.9.2.3 Silt excluders shall be checked for floatation and sliding also with no silt load on top of the tunnels and no water inside all the tunnels.

5.10 Gates

5.10.1 The gates of the barrages are generally of the fixed wheel type or radial type. For design of these types of gates, reference may be made to IS : 4622-1978* and IS : 4623-1967†.

5.11 Head Regulators

5.11.1 The head regulators of the diversion structure shall be designed in accordance with the provisions of IS : 6531-1972‡. For design of the various components of the head regulators like abutment, raft, pier, cut-off, return wall, etc, the criteria outlined for the main diversion structure under the relevant clauses of this standard shall apply.

*Recommendations for structural designs of fixed-wheel gates (*first revision*).

†Recommendations for structural design of radial gates.

‡Criteria for design of canal head regulators.

5.11.1 *Breast Wall*

5.11.2.1 Wherever the high flood level upstream of the barrage/weir is higher than the pond level, from economical considerations of the height of the gates of the head regulator, breast wall is generally provided above the pond level up to at least the free board level. The breast wall consists of two portions, namely, beam and stem. The beams span the waterway of the head regulator in the space between the stoplog and main gate grooves.

5.11.3 *Design*

5.11.3.1 The beam of the breast wall spanning between the pier and abutment/pier shall be designed to resist the moments due to :

- a) Dead load of the breast wall;
- b) Uplift;
- c) Water pressure;
- d) Seismic forces and moments, if any; and
- e) Hydrodynamic forces due to seismic conditions, if any.

It shall be designed to resist the moments in both horizontal and vertical directions.

5.11.3.2 The beam shall be checked for torsional moments also and suitably reinforced.

5.11.3.3 The stem shall also be designed as per the criteria for the design of beam given in 5.11.3.1 and 5.11.3.2. The stem may also be checked as a deep beam subjected to the various loads and moments though generally it may not govern the requirements of reinforcement.

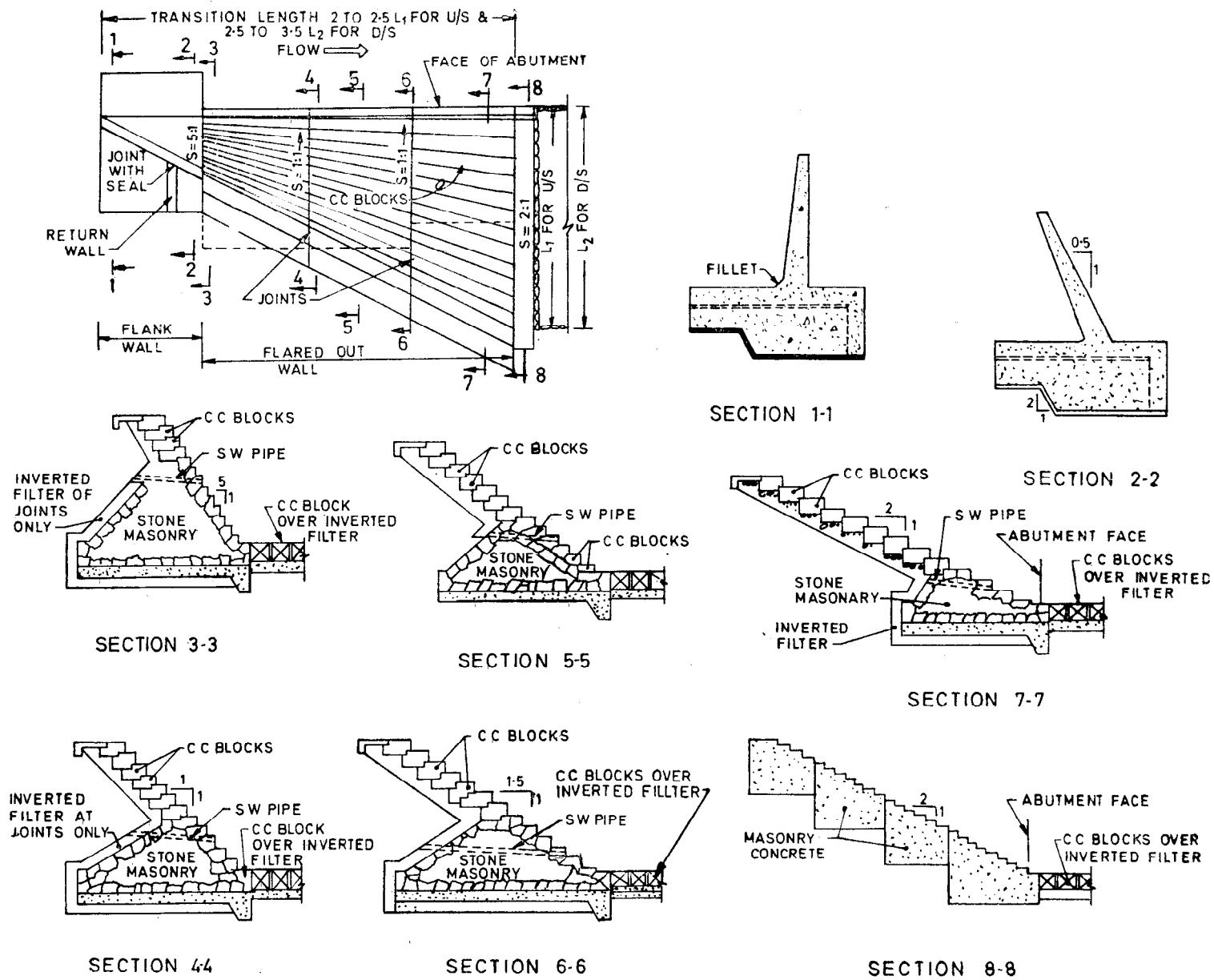

All dimensions in millimetres.

FIG. 3 TYPICAL DETAILS OF FLANK AND FLARED OUT WALLS

As in the Original Standard, this Page is Intentionally Left Blank

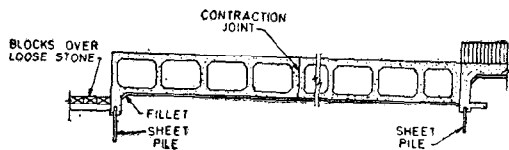
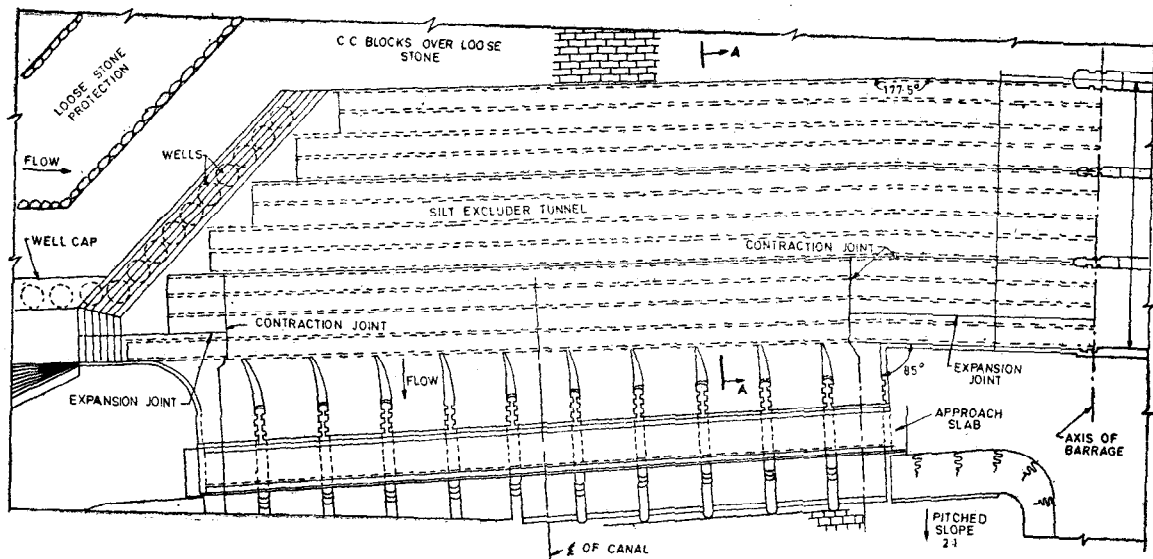

SECTION A A

FIG. 4 SILT EXCLUDER BAYS IN A BARRAGE TYPICAL LAY-OUT AND SECTION

INTERNATIONAL SYSTEM OF UNITS (SI UNITS)

Base Units

<i>Quantity</i>	<i>Unit</i>	<i>Symbol</i>
Length	metre	m
Mass	kilogram	kg
Time	second	s
Electric current	ampere	A
Thermodynamic temperature	kelvin	K
Luminous intensity	candela	cd
Amount of substance	mole	mol

Supplementary Units

<i>Quantity</i>	<i>Unit</i>	<i>Symbol</i>
Plane angle	radian	rad
Solid angle	steradian	sr

Derived Units

<i>Quantity</i>	<i>Unit</i>	<i>Symbol</i>	<i>Definition</i>
Force	newton	N	1 N = 1 kg. m/s ²
Energy	joule	J	1 J = 1 N.m
Power	watt	W	1 W = 1 J/s
Flux	weber	Wb	1 Wb = 1 V.s
Flux density	tesla	T	1 T = 1 Wb/m ²
Frequency	hertz	Hz	1 Hz = 1 c/s (s ⁻¹)
Electric conductance	siemens	S	1 S = 1 A/V
Electromotive force	volt	V	1 V = 1 W/A
Pressure, stress	pascal	Pa	1 Pa = 1 N/m ²